

DBS-11A

Replacement Parts

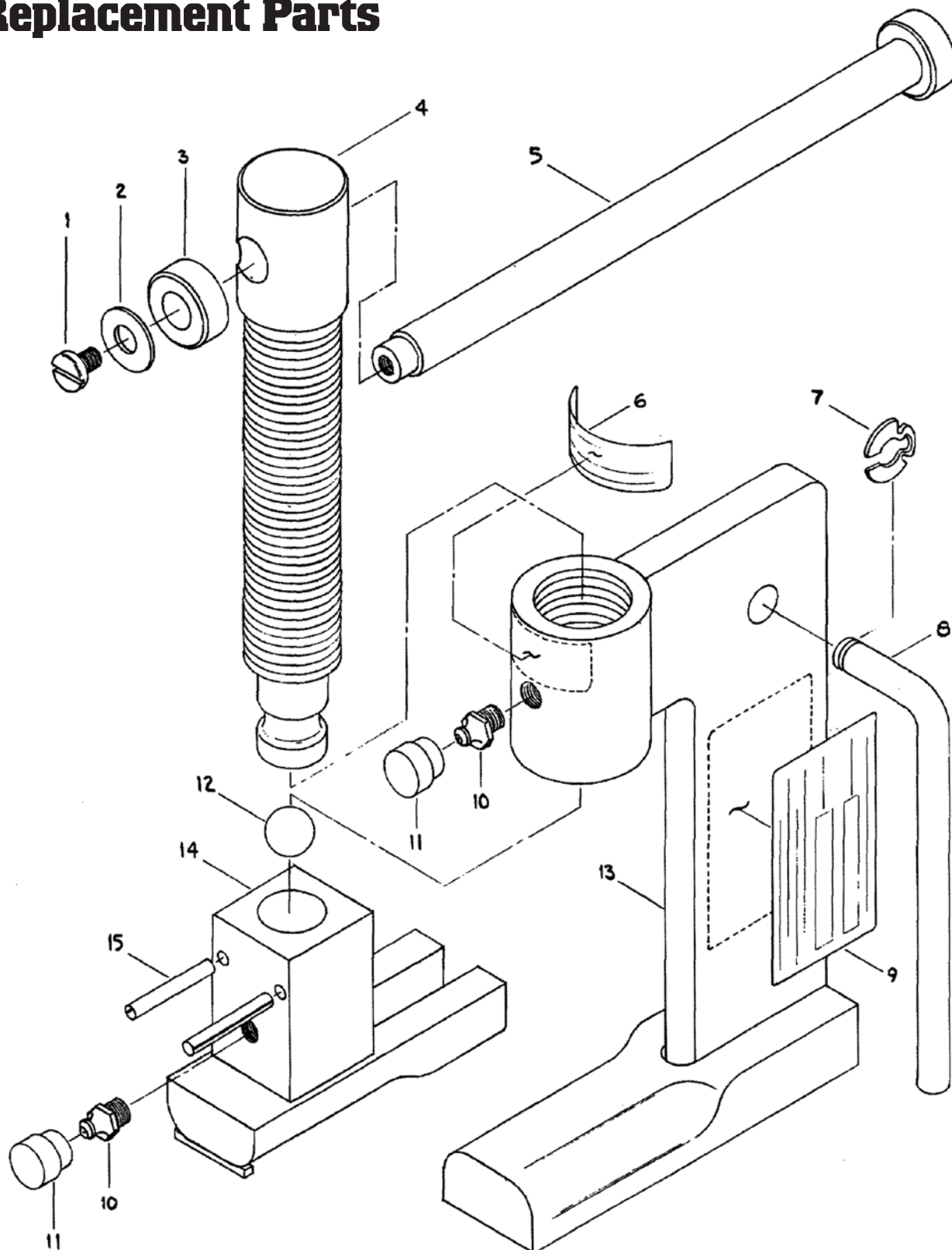

MUSTANG
Squeeze Tools

2401 Lockheed Way
Carson City, NV 89706

775.883.0732 Tel
775.883.3372 Fax

mustangmfg@gbis.com
www.squeezetool.com

DBS-11A

Replacement Parts

Item	Description	Qty.	Part#
1	10-32 x 3/8" Slotted Pan Head Screw	1	5-11
2	#10 Flat Washer	1	9-11
3	Handle Button	1	6-11
4	Power Screw	1	2-11
5	Handle, 7" Long	1	4-11
6	Nameplate, Caution/Center	1	10-11
7	Retaining Ring, Torque Arm	1	5304-37
8	"L" Torque Handle	1	13-11
9	Nameplate, Model/Capacity	1	N-3
10	Grease Fitting	2	P-7
12	Ball Bearing	1	7-11
13	Frame	1	1-11
14	Upper Jaw	1	3-11
15	3-16" Dia. x 1" Roll Pin	2	P-6
16	Handle Assembly, Complete	1	8-11A