

DBM -60 Replacement Parts Tool Frame

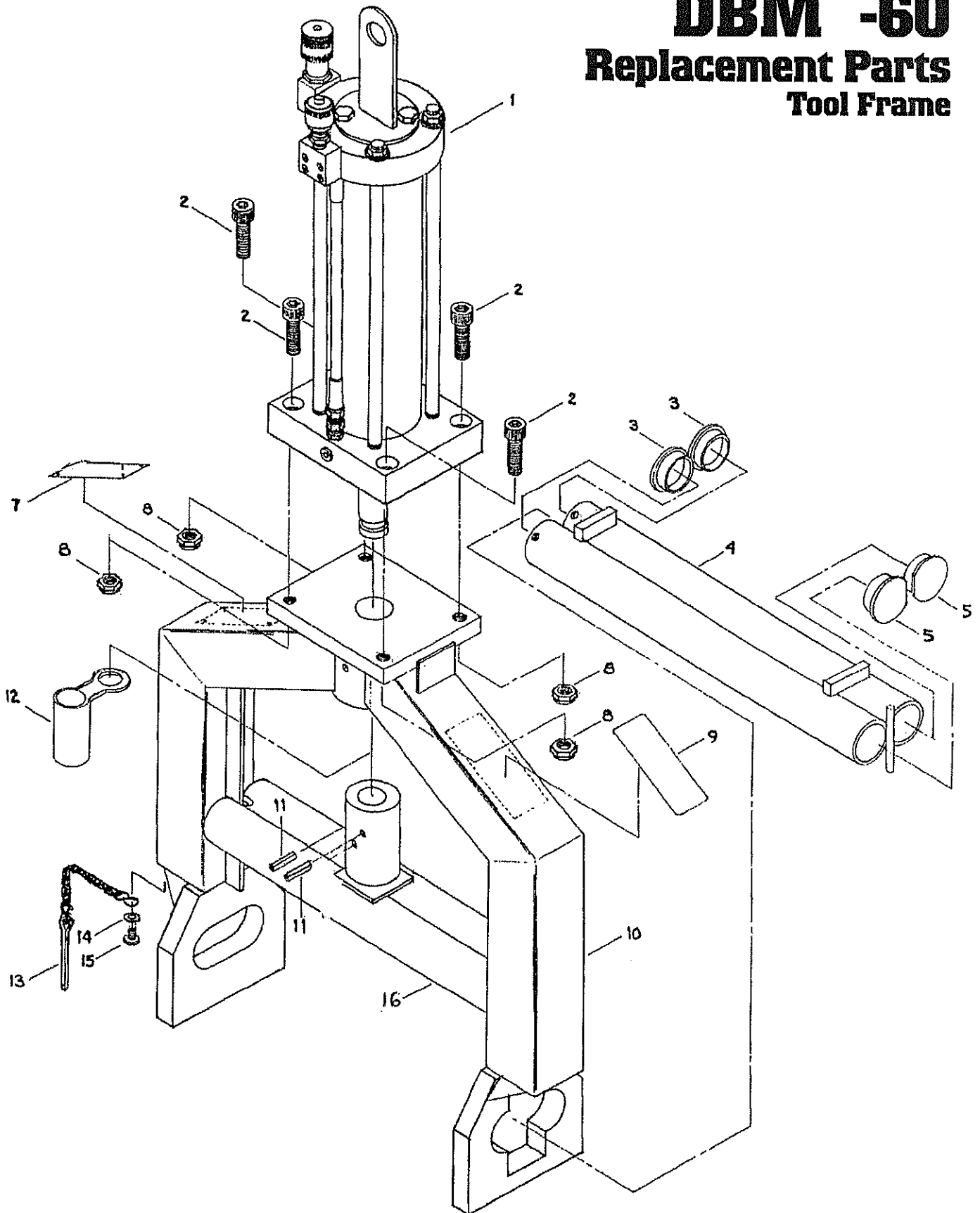

MUSTANG
Squeeze Tools

2401 Lockheed Way
Carson City, NV 89706

775.883.0732 Tel
775.883.3372 Fax

mustangmfg@gbis.com
www.squeezetool.com

**MUSTAM MODEL DBM-60
MANUAL SQUEEZE TOOL PARTS LIST**

ITEM	DESCRIPTION	QTY.	PART NO.
1	Hydraulic Cylinder Assembly	1	HCML-60
2	5/8"-11 NC x 2" Soc. Head Cap Screw	4	CPS-2
3	Lower Jaw End Cap - SIZE (Please specify sizes)	2	LJC-3
4	Lower Bar - (Please specify sizes)	1	LJ-60
5	Lower Jaw End Cap - (Blank)	2	LJE-5
6	Nameplate - Model & Capacity (Please specify sizes)	1	MCL-6
8	5/8"-11 NC Locking Hex Nut	1	LHN-8
9	Nameplate - Hydraulic Operation	1	MHO-9
10	Frame Assembly -(w/o upper/lower jaw & cylinder)	1	FA-10
11	1/4" Dia. X 1 1/2" Roll Pin	2	RP-11
12	SEG-30 Static Ground Spike Holster	1	SG-10
13	Cotter Pin Chain Assembly	1	CA-13
14	5/16" Flat Washer SAE	1	FW-14
15	1/4"-20NC x 3/8" Slotted Pan Head Screw	1	CPS-15
16	Upper Jaw Assembly	1	UJ6-18